

Solar Energy South Africa

Photovoltaic energy storage discharge duration



Overview

What are the energy storage options for photovoltaics?

This review paper sets out the range of energy storage options for photovoltaics including both electrical and thermal energy storage systems. The integration of PV and energy storage in smart buildings and outlines the role of energy storage for PV in the context of future energy storage options.

Can energy storage systems reduce the cost and optimisation of photovoltaics?

The cost and optimisation of PV can be reduced with the integration of load management and energy storage systems. This review paper sets out the range of energy storage options for photovoltaics including both electrical and thermal energy storage systems.

How to optimize a photovoltaic energy storage system?

To achieve the ideal configuration and cooperative control of energy storage systems in photovoltaic energy storage systems, optimization algorithms, mathematical models, and simulation experiments are now the key tools used in the design optimization of energy storage systems 130.

How photovoltaic energy storage system can ensure stable operation of micro-grid system?

As an important part of the micro-grid system, the energy storage system can realize the stable operation of the micro-grid system through the design optimization and scheduling optimization of the photovoltaic energy storage system. The structure and characteristics of photovoltaic energy storage system are summarized.

Can energy storage be used for photovoltaic and wind power applications?

This paper presents a study on energy storage used in renewable systems, discussing their various technologies and their unique characteristics, such as

lifetime, cost, density, and efficiency. Based on the study, it is concluded that different energy storage technologies can be used for photovoltaic and wind power applications.

What is a photovoltaic energy storage system (PV-ESS)?

With the rapid development of renewable energy, photovoltaic energy storage systems (PV-ESS) play an important role in improving energy efficiency, ensuring grid stability and promoting energy transition.

Photovoltaic energy storage discharge duration



Design and Control Strategy of an Integrated Floating ...

A novel integrated floating photovoltaic energy storage system was designed with a photovoltaic power generation capacity of 14 kW and an energy storage capacity of 18.8 kW/100 kWh. (MPPT) mode. All four ...

'Longer-duration storage' and its role in the future of ...

The longer the desired discharge duration, the more challenging it is to apply storage. Why is that? Let's have a look at demand, cost and regulatory support of systems aiming for a discharge from multiple days up to ...



Solar Energy Storage Systems: Everything You Need ...

Delve into the future of green energy with solar energy storage systems, including their

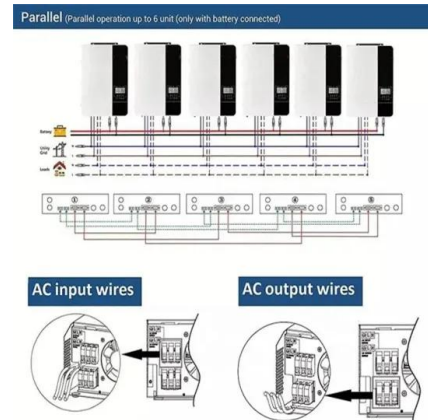

Battery Energy Storage System (BESS) , The Ultimate ...

Rated Energy Storage Capacity is the total amount of stored energy in kilowatt-hours (KWh) or megawatt-hours (MWh). Capacity expressed in ampere-hours (100Ah@12V for example). Storage Duration. The amount of time storage can ...

incredible benefits and innovative technologies. These systems store electricity in batteries during periods of excess solar energy ...



BESS Basics: Battery Energy Storage Systems for PV ...

The energy storage system of most interest to solar PV producers is the battery energy storage system, or BESS. While only 2-3% of energy storage systems in the U.S. are BESS (most are still hydro pumps), ...

Contact Us

For catalog requests, pricing, or partnerships, please visit:
<https://www.ian-solar.co.za>